

Gaia PASTICCERIA ST/LX

Vetrina pasticceria a refrigerazione ventilata. Chiusura lato operatore tramite tendina manuale autoavvolgente.



REFRIGERANTE
R452A



ILLUMINAZIONE
Led



INSTALLAZIONE
Plug-in



TEMPERATURA (°C)
+1/+10



SBRINAMENTO
Automatico



CLASSE CLIMATICA
3



ST

DOTAZIONE DI SERIE

Piedini livellanti

Vetri in cristallo temprato

Profilo plafoniera in alluminio anodizzato
colore argento

Piano espositivo e piano di servizio
in acciaio inox finitura lucida

Quadro comandi elettronico

Illuminazione interna orizzontale

Fianco laterale colore grigio E_Z065

Termometro digitale in vasca

OPTIONAL

Kit ruote

PANNELLO FRONTALE - COLORI DISPONIBILI (FINITURE LACCATE)

Grigio E_Z065	Blu Cielo RAL 5005	Bianco RAL 9003	Orange RAL 2001	Beige Perlato RAL 1035	Rosso RAL 3020	Lemon RAL 1032	Alluminio RAL 9006

PANNELLO FRONTALE - ADESIVI

Millefiori Orange	Millefiori Bianco	Millefiori Black



LX

ST

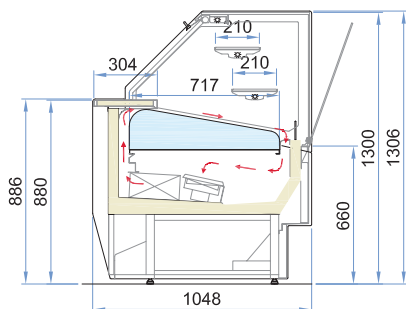

LX

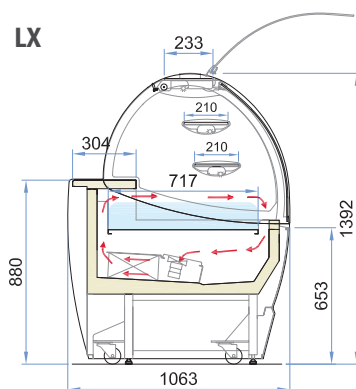

MODELLO		110	164	218
		RV	RV	RV
Dimensioni esterne	L x P x H	mm ST	1103 x 1048 x 1306	1643 x 1048 x 1306
		mm LX	1103 x 1063 x 1392	1643 x 1063 x 1392
Refrigerante		R452A	R452A	R452A
Refrigerazione		Ventilata	Ventilata	Ventilata
Capacità	Lorda - Netta	lt	400 - 150	590 - 220
Temperatura prodotto		°C	+1 / +10	+1 / +10
Sbrinamento			Fermata compressore	Fermata compressore
Classe climatica		N°	3	3
Condizioni ambientali		°C/%RH	25 / 60	25 / 60
Compressore	Tipo - N°		Ermetico - 1	Ermetico - 1
Alimentazione		V/ph/Hz	230 / 1 / 50	230 / 1 / 50
Assorbimento elettrico	Regime	W/A	680 / 4	950 / 5,5
	Sbrinamento	W/A	360 / 1,7	380 / 1,8
Peso netto		kg	235	315